

# the **CrossFit** JOURNAL ARTICLES

## Indoor Rowing

### Damper Settings and Workout Intensity

Peter Dreissigacker

People often ask us at Concept2 what the damper on our rower does and where to set it for the best workout. The damper setting is important, but it does not determine how much actual work you are doing when you row.

Selecting a damper setting is not like selecting how much weight to put on a bar. In the case of the bar, if for one workout you load it with 100 pounds and lift it 10 times, and for the next workout you put 110 pounds on for 10 reps, you have clearly done more work in the second workout. The rower, or “erg,” is different. It does not determine how much work you do; rather, it responds to the amount of force you put into the exercise. The more force you put into each stroke, the more resistance you will feel.

Rowing on the erg is really about producing power, and here I would like to clarify what I mean by power. Power is often confused with force, and, although related, they are different. Force applied over a distance yields work. Work integrated over time yields power. By this definition, lifting 10 pounds two feet is the same amount of work as lifting 20 pounds one foot. And if both those lifts are accomplished in one second, they require the same amount of power. Obviously, the speed movement of the two-foot lift would be greater than the speed of the one-foot lift if they both take one second. When a rower does a 500-meter test, the 500 meters represents the amount of work they will do. Everyone doing the 500 meter test will do the same amount of work, regardless of the damper setting. The rower who does that work in the least amount of time

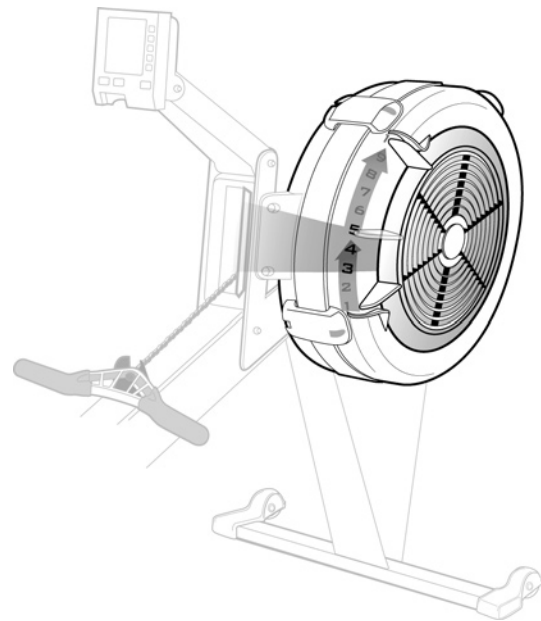

will generate the most power. So an athlete who is using the erg to train for maximum power output should set the damper where they can go a given distance in the shortest time. That is how they will generate the most power.

Much like selecting a gear on a bicycle, setting the rower's damper is a personal choice. You should experiment with different damper settings to find the setting that gives you the best workout and results.

1 of 3

## Damper Settings and Workout Intensity (continued...)

At any damper setting, though, you can choose to row easy or row hard. Most people initially prefer to use the higher damper settings (7 to 10) for rowing hard because they don't have to move as fast to generate a lot of power. Moving more slowly gives you more time during the drive to coordinate the stroke. At a low damper setting (1 to 3), you need to coordinate your drive more quickly in order to generate power. Rowing at a high stroke rate is another way of "moving faster to generate higher power," but there is a trade-off as "wasted energy" becomes a factor, particularly if your goal is to achieve your best time for a set distance.

Some coaches of top rowers (big guys scoring in the 6:00 range for 2000 meters) insist that their athletes' off-water winter training be done at the lower damper settings so that they train at delivering high force quickly—which translates into making a boat go fast rather than being a big and strong but slow team. This is done specifically for improving boat speed on the water, but keep in mind that these are "power athletes"; their goal is to produce the most power to propel the craft as fast possible.

### How the damper works

It may be helpful to know how the Concept2 rower creates the workload you feel when you pull the handle. As you apply force, you are both accelerating the mass of the flywheel and working against the air resistance of the spinning fan. On the recovery portion of your stroke, air resistance slows the flywheel down. The damper controls the amount of air that the fan can move. The more air that has to be moved, the more resistance is generated for a given fan speed. So, opening the damper (setting it to a high number) has two effects that make your drive feel heavier: You are working against greater air resistance for a given fan speed, and the flywheel slows down more during the recovery, meaning that you will have to get it moving again from

a slower starting speed on your next pull. Closing the damper (setting it to a lower number) reduces the air that the fan has to move, so you must get the fan spinning faster in order to generate the power. It's more like rowing a fast-moving boat where the rower has to be quick in applying force to make the boat go even faster.

Finally, the electronic monitor has the job of measuring all these factors and calculating the work so that the readout gives comparable results regardless of where the damper is set. This assures that two athletes rowing the same distance in the same time are in fact putting out the same amount of power. If the setting is lower, the rower will have to be pulling more quickly during the drive, and perhaps (but not necessarily) rowing at a higher stroke rate.

You can experience what I mean by this last point the next time you get on an erg. Pick a pace (time per 500 meters) and a stroke rate that is comfortable for you to maintain—perhaps something like a 2:00 pace and 28 strokes per minute. (Note: the monitor displays the "pace" of each stroke in the center display window and strokes per minute in the upper right). During this demonstration you will try to make every stroke at the 2:00 pace and hold a constant stroke rate of 28. Start in a high damper setting and maintain this for a minute, then switch to a lower setting and get back into the 2:00 pace at 28 strokes per minute. First, you will be able to feel the difference in the quickness of your movement during the drive. You will also be taking more time coming back up the slide on the recovery. The goal of this exercise is to prove to yourself that the same power can be generated at different damper settings and at the same stroke rate. You will need higher force during the drive in a higher damper setting, but the speed of your pull through will be slower.

*Rowing at a high stroke rate is another way of "moving fast to generate higher power," but there is a trade-off as "wasted energy" becomes a factor.*



## Damper Settings and Workout Intensity (continued...)

In practice, an athlete will generally row at a lower stroke rate when rowing in the high damper settings. This is because more time is spent on the drive, requiring a rush back up the slide on the recovery in order to achieve a high stroke rate. A rushed recovery can result in wasted energy and leave the athlete unprepared to deliver a best effort on the next drive.

It is important to note that, unlike weightlifting, the goal is not to use a higher drag factor as a means of achieving fitness on the indoor rower. If your goal is to train for maximum power output, I suggest trying different damper levels and drag settings, while improving your speed, form, and muscle coordination, to discover where you can achieve the highest power output. This will be where you are able to get your best time for a test distance.

### **Fine tuning the damper setting by adjusting the drag factor**

In addition to choosing a damper setting, you can also adjust the drag factor of each rower. Drag factor is a numerical value for the rate at which the flywheel decelerates. This number changes with the volume

of air that passes through the flywheel housing. Since higher damper settings allow more air into the flywheel housing, the flywheel decelerates more quickly, resulting in a higher drag factor value. The PM measures the drag factor on the recovery phase of each stroke and uses it to calculate your score (in the units you care about: time, distance, pace, or wattage). This method of “self-calibration” compensates for local conditions and damper settings, making scores on different rowers truly comparable. Indoor racing and the online community and rankings are made possible by this self-calibration.

However, because it is compensating for a number of environmental factors (such as temperature, altitude, wind, and lint accumulation inside the flywheel cover), drag factor settings can make different rowers feel different even at the same damper setting. So on an unfamiliar indoor rower, you may need to change the damper setting to make it feel “right” to you.

For more detailed information on drag factor and how to view it on your rower’s monitor, see “Understanding Drag Factor” at <http://www.concept2.com/us/training/tools/dragfactor.asp>.



Peter Dreissigacker, along with his brother Dick, founded [Concept2](http://www.concept2.com) as an oar manufacturer in 1976. In 1981, they developed the first Concept2 indoor rower, which rapidly became the standard for wind-resistance indoor rowers. In addition to his work at Concept2, Peter continues to row competitively both on and off the water, with some backcountry skiing for variety in the winter. He also makes time for painting and drawing, and at 55, is a novice piano student and closet accordion player.

The February issue of the *CrossFit Journal* included Peter’s article, “How to Prepare for an Erg Test,” in which he stated his goal of finishing the 2000-meter race at February’s C.R.A.S.H.-B. Sprints in under 6:40. He is happy to report that his time of 6:39.2 placed him fourth in the 55-to-59 age category.